

**PARS-HUB-2000**

**Electrical Properties**

Rated Output Power (W):	2000
Rated Speed (Rpm):	625
Nominal Voltage (V):	48
Efficiency(%):	91.25
Maximum Output Power (W):	7824
Average Input Current (A):	45.6

**Mechanical Properties**

Weight (Kg) :	24
Rotor Position :	Outside
Insulation :	Class H

**Material Properties**

Shaft Materials :	High Standard Stainless Steel
Shaft Roller Type	
Outer Frame Material	High Standard Aluminum Alloy
Connectors (Nut/Bolt):	High Standard Stainless Steel

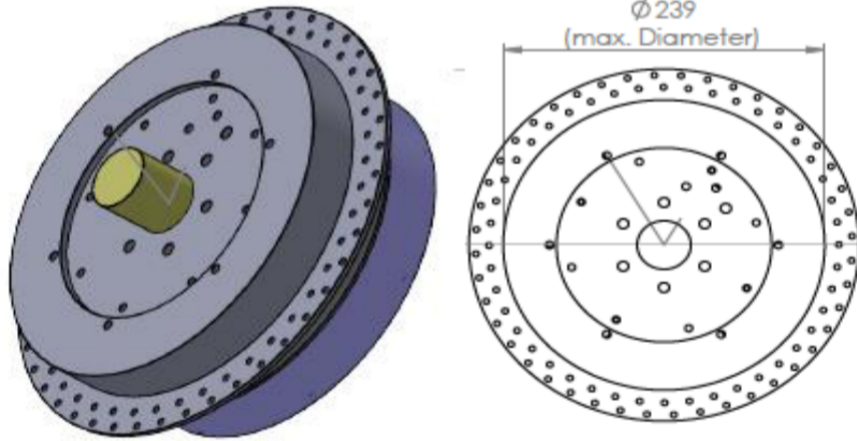

**Efficiency**

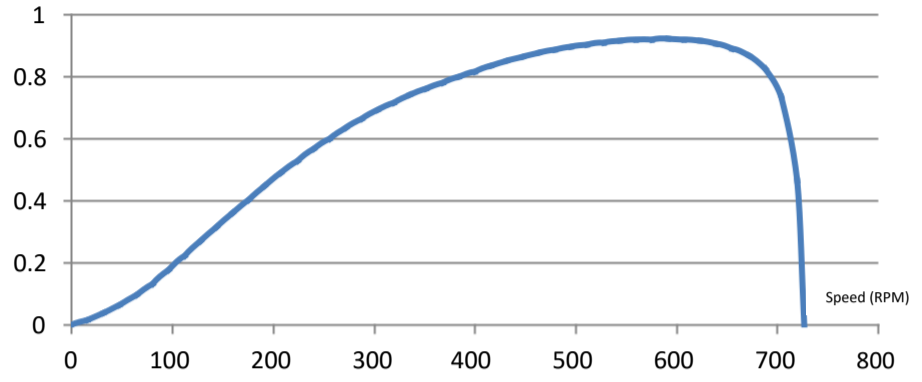

**Output Power [kW]**

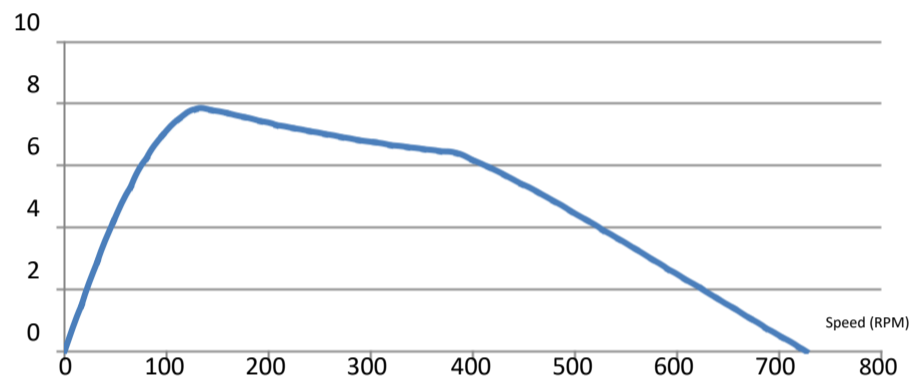

**Torque [N.m]**

